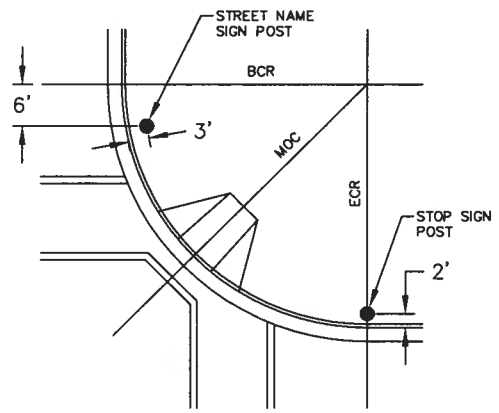

TABLE 1: LETTER & BLADE SIZE

MOUNTING TYPE	SPEED LIMIT	MINIMUM LETTER HEIGHT		SUFFIX		BLADE SIZE (E)
		INITIAL UPPER-CASE (A)	LOWER CASE (B)	INITIAL UPPER-CASE (C)	LOWER CASE (D)	
POST-MOUNTED	40 MPH OR LESS	6 INCHES	4.5 INCHES	3 INCHES	2.25 INCHES	9 INCHES
POST-MOUNTED	MORE THAN 40 MPH	8 INCHES	6 INCHES	4 INCHES	3 INCHES	12 INCHES

TABLE 2: STD SUFFIXES

SUFFIX	ABBREV
AVENUE	Ave
BOULEVARD	Blvd
CIRCLE	Cir
COURT	Ct
DRIVE	Dr
LANE	Ln
PARKWAY	Pkwy
PLACE	Pl
ROAD	Rd
STREET	St
TERRACE	Ter
TRAIL	Tr
WAY	Way



TYPICAL LOCATION OF STREET NAME AND STOP SIGNS

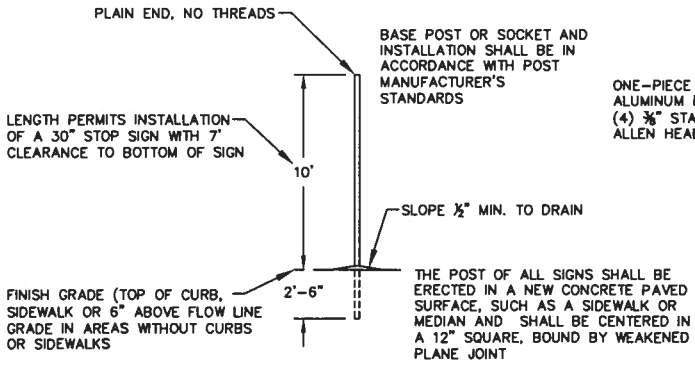
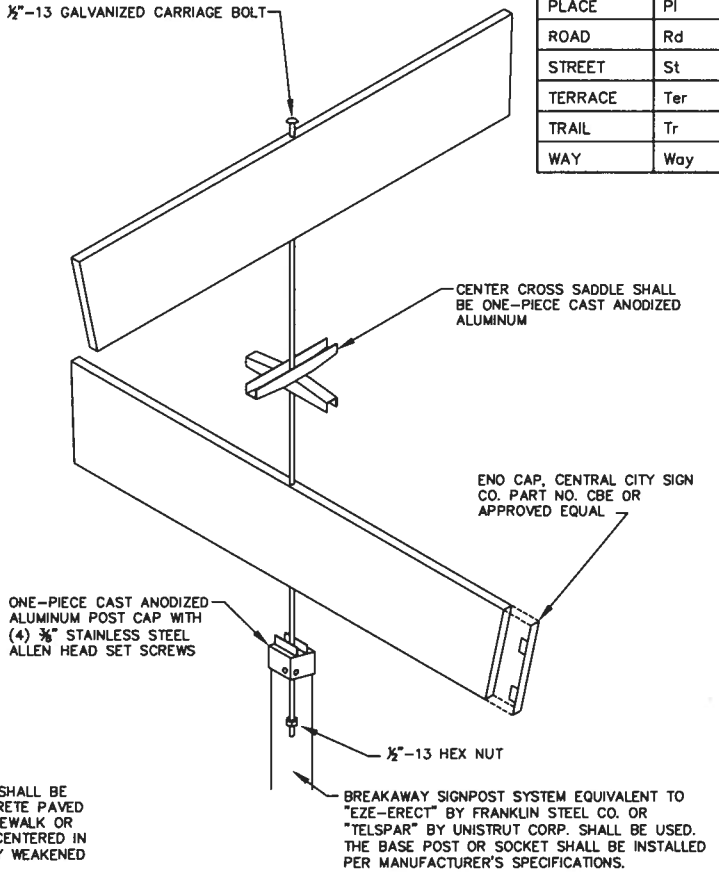

INSTALLATION DETAILS

APPROVED BY: *[Signature]* DATE: 5/18/11

CITY ENGINEER

MARK	REVISIONS	APPR.	DATE

CITY OF RIVERSIDE
PUBLIC WORKS DEPARTMENT

STREET NAME SIGNS (MAJOR & MINOR STREETS)

STANDARD DRAWING NO. 662
Sheet 1 of 1