

# City of Riverside

Building & Safety Division

Phone: (951) 826-5697

[www.riversideca.gov](http://www.riversideca.gov)

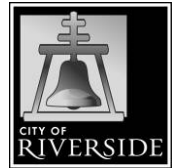

## ❖ Water Heater Installations ❖

(Selected excerpts from the 2010 California Plumbing Code)

### CPC 508.2 - Seismic Strapping of Water Heaters:

Strapping shall be at a point within the upper 1/3 and the lower 1/3 of the water heater's vertical dimensions. At the lower point, a minimum distance of four (4) inches shall be maintained above the controls to the strap. Other methods and location may be acceptable, check with the Building & Safety Division.

### CPC 608.5 - Temperature and Pressure (T & P) Relief Valve:

T & P relief valves shall be provided with a drain to the outside of the building, not smaller than the relief valve outlet, of either galvanized steel, hard-drawn copper, CPVC, or listed relief valve drain tube. For more information on the termination of the T & P valve piping see reverse side.

### CPC 510.6.1.1 - Water Heater Venting:

Type B gas vents shall extend in a generally vertical direction with offsets not exceeding 45 degrees, except that a vent system having not more than one 60 degree offset shall be permitted. Any angle greater than 45 degrees from the vertical is considered horizontal. The total horizontal distance of a vent, plus the horizontal vent connector serving draft-hood equipped appliances, shall not be greater than 75 percent of the vertical height of the vent.

### CPC 510.6.2.1 - Water Heater Venting:

Type B gas vents shall terminate at least 5 feet in vertical height above the water heater.

### CPC 510.6.2 (1) - Water Heater Vent Termination:

Vents shall terminate above the roof surface at a listed cap or listed roof assembly. Provide at least 8 feet horizontal clearance from any opening into the building.

### CPC 508.14 - Water Heaters in Garages:

Water heaters in garages and in adjacent spaces that open to a garage shall be installed so that all burners and burner-ignition devices are located not less than 18 inches above the floor, unless listed as flammable vapor ignition resistant. Water heaters shall be located or protected so that they are not subject to physical damage by a moving vehicle.

### CPC 507.4.1 - Combustion Air Openings:

Two permanent openings, one commencing within 12 inches of the top and one commencing within 12 inches of the bottom of the water heater enclosure shall be provided. The openings shall communicate directly, or by ducts, with the outdoors or spaces that freely communicate with the outdoors. Combustion air openings shall not be less than 100 square inches.

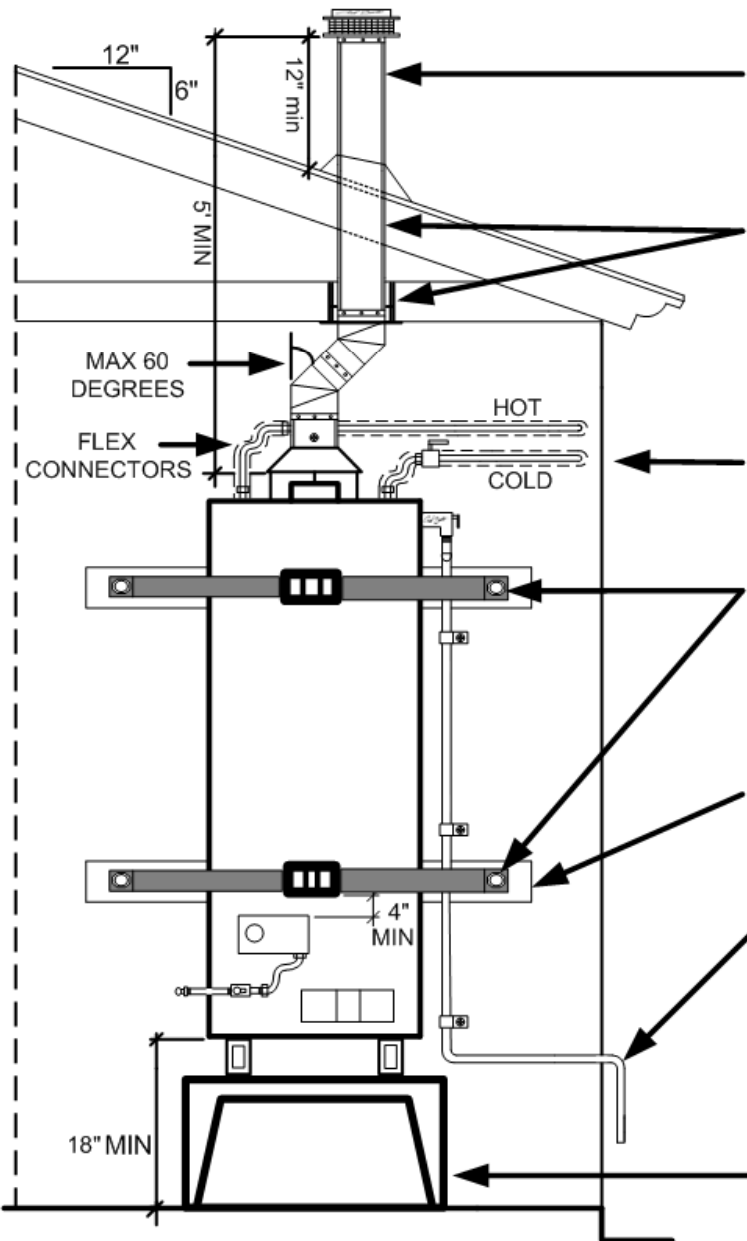
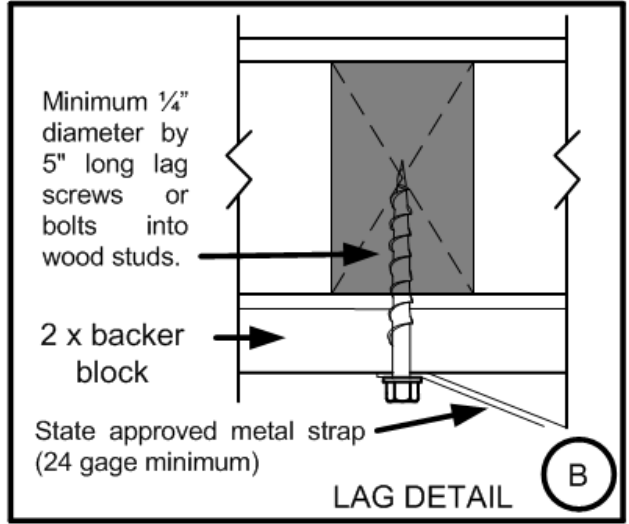
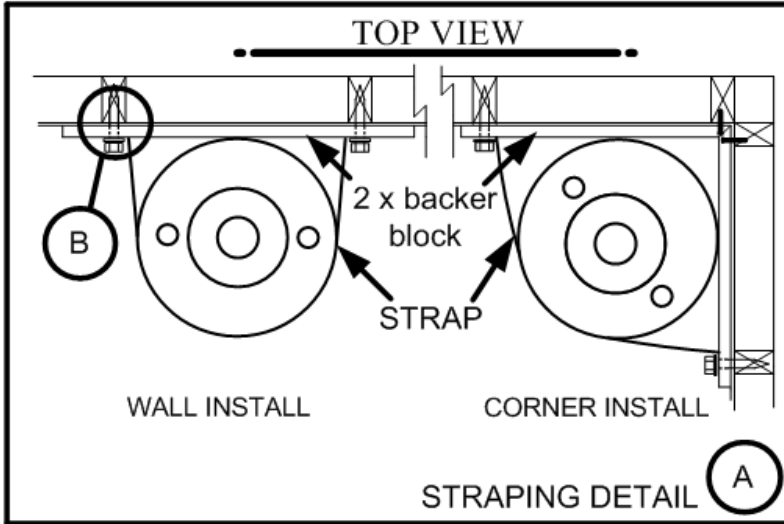

Venting for the water heater shall be Type B (double wall) vent pipe and shall terminate at least 5 feet above the draft hood or flue collar and at least 12" above roof. (steeper pitched roofs will require additional clearances)

Provide minimum 1" clear space from vent to any combustible materials. When type B water heater vent is installed in an attic, provide approved ceiling thimble for the double wall vent. NO single wall vents allowed in attic.

Insulate pipes (hot & cold) within the first 5' feet of the water heater.

Strapping shall be within the upper 1/3 and the lower 1/3 of the water heater. At the lower point, a minimum distance of 4" inches shall be maintained between the controls and the lower strap. Other methods may be acceptable, check with the Building Inspector. See strap and lag detail above.

Provide a 2 x backer block top and bottom behind water heater for support if there is no stud directly behind the water heater. See detail (A)

Temperature and pressure (T&P) relief valve piping shall extend from the valve to the outside of the building with end of pipe not more than 24" nor less than 6" from the ground. Other methods and locations may be acceptable, check with the Building Inspector. Piping shall be of galvanized steel, hard-drawn copper or CPVC.

Gas water heaters in residential garages must be a minimum of 18" above the floor to the burner device. Additionally, water heaters installed in garages shall be protected so as to not be subject to physical damage by a moving vehicle.