

STRAIGHT RUN

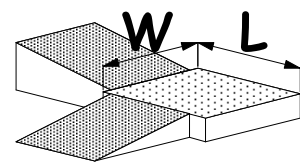

90 DEGREE TURN

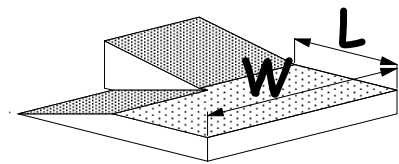

180 DEGREE TURN

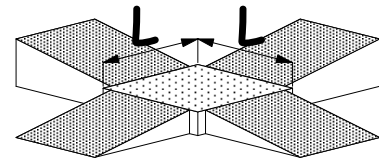

INTERSECTING RAMPS

INTERMEDIATE LANDINGS at RAMPS

RAMP CONFIGURATION	LANDING LENGTH(L)	LANDING WIDTH(W)	NOTES
STRAIGHT RUN	5'-0" min.	4'-0" min.	1, 2, 3, 4
90 DEGREE TURN	6'-0" min.	5'-0" min.	1, 2, 3
180 DEGREE TURN	6'-0" min.	8'-0" min.	1, 2, 3
INTERSECTING	6'-0" min.	—	1, 2, 3

NOTES:

- HANDRAILS AND GUARDS HAVE BEEN OMITTED FOR CLARITY.
- LANDINGS AT EXTERIOR LOCATIONS MAY HAVE UP TO A MAXIMUM 2 PERCENT SLOPE AND CROSS-SLOPE.
- FOR ENCROACHMENT OF DOORS ONTO LANDINGS, SEE DETAIL "B".
- A CHANGE OF DIRECTION NOT EXCEEDING 30 DEGREES IS CONSIDERED A STRAIGHT RUN.

INTERMEDIATE LANDINGS at RAMPS

A

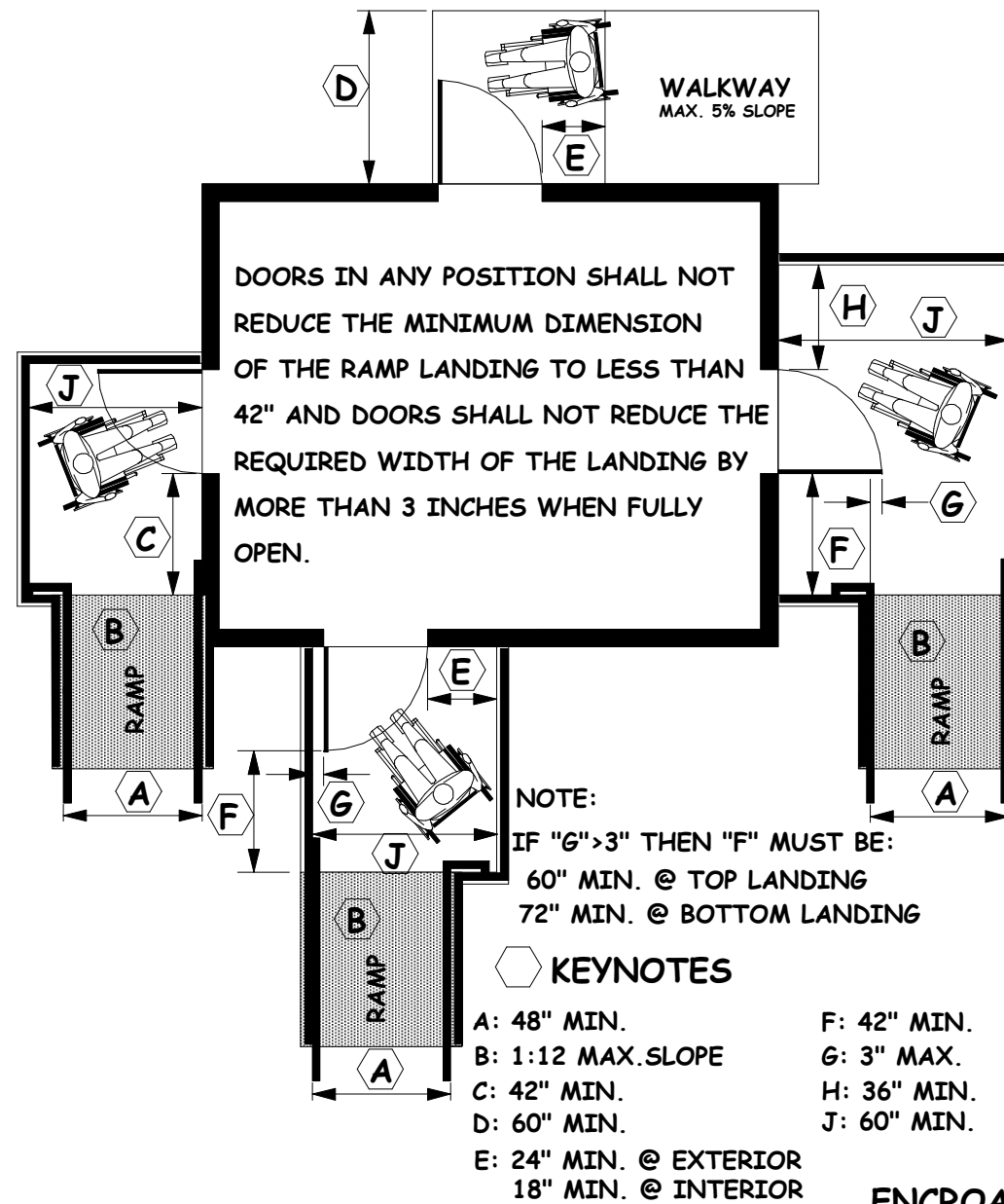

ENCROACHMENT OF DOORS ONTO LANDINGS

B

1-1/4" TO
1-1/2" DIA. 1-1/2"

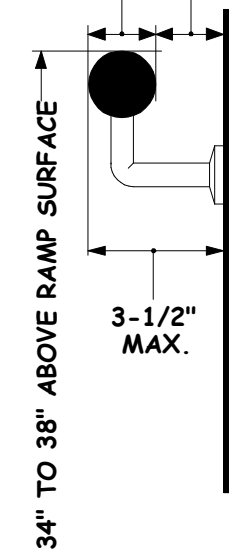

MINIMUM HANDRAIL REQUIREMENTS

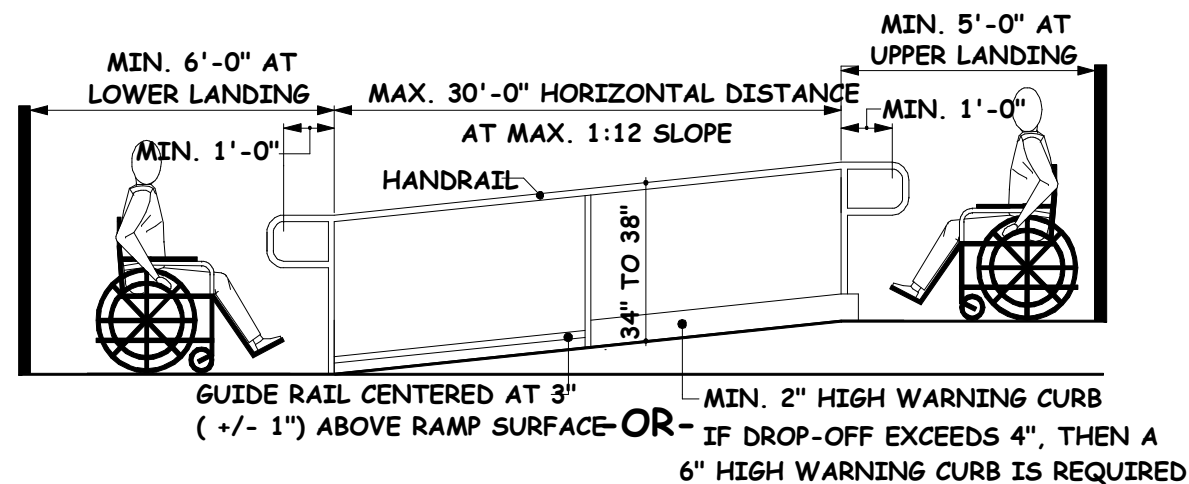

HANDRAIL and GUARD REQUIREMENTS

C

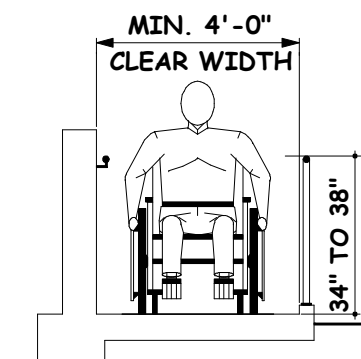

City of Riverside
Building & Safety Division
DISABLED ACCESS STANDARDS

SCALE **NONE**

PGH 6 / 02
DRAWN DATE

REV.	DATE	APPR.
1	01-01-11	PGH
2		
3		
4		
5		

ACCESSIBLE RAMPS & LANDINGS

RDA - 2.0

SHEET